

XP 40 / 60 / 80 Air Pump



- Pressure type
- Dust control "Dust trap filter"
- Easy restart by micro switch (XP-60 / 80 only)
- No need of grounding
- Outdoor (Rainproof) use

Applications

- Septic tank (biological contact aeration)
- Air injection for bubble bath
- Small capacity compressor

Dimensions

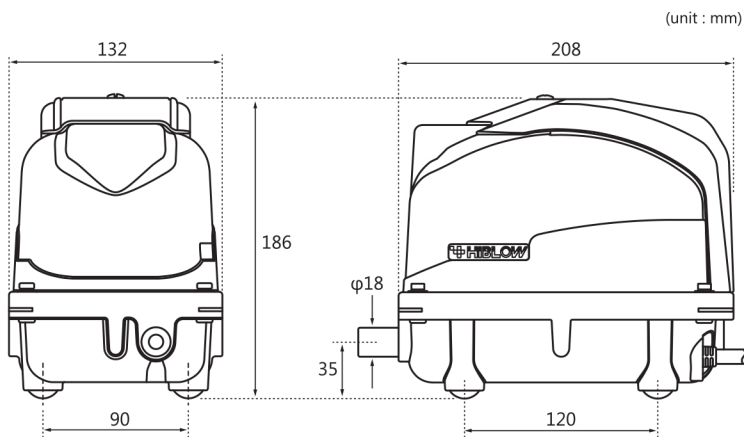

Specifications

| | XP-40 | XP-60 | XP-80 |
|--------------------------|-------------------|---------|---------|
| Rated voltage [V] | AC100 / 120 / 230 | | |
| Power frequency [Hz] | 50 60 | 50 60 | 50 60 |
| Rated pressure [kPa] | 12.8 | 14.7 | |
| Airflow volume [L/min] | 40 | 60 | 80 |
| Power consumption [W] | 30 | 39 | 58 |
| Sound level [dBA] | 33 | 35 | 36 |
| Weight [kg] | 4.1 | 4.3 | |

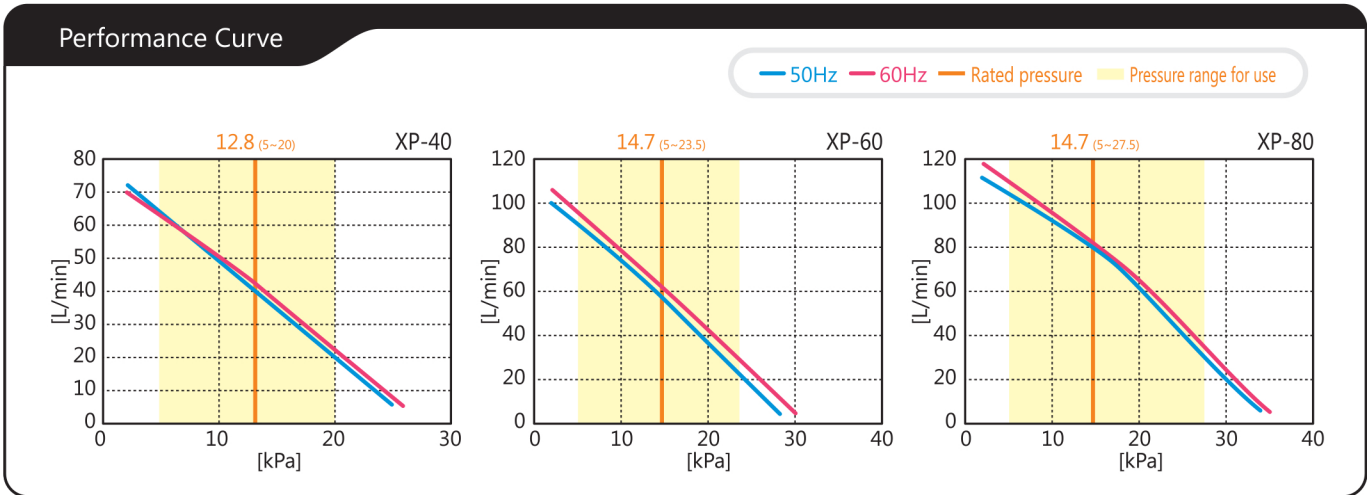

* All characteristics values are only for reference, and are not guaranteed values.
 * Note that the operating temperature for our pumps is 41°F(5°C) to 104°F(40°C).