

Section A-A

Rated to continuous flow of 1600 litres per day. Up to 2000 litres per day for intermittent use.

Lid thickness standard at 80mm. Recommended maximum loose soil cover depth - 400mm

Light Trafficable and heavy duty lids with cast iron frame and grates are available to order. Contact Austin Bluewater technical department.

TANK Weight - including 80 mm lid = 8.2 tonne
Lifting - 4 number Reid 2.5 t eye anchors When handling an equalising beam must be used to ensure equal loading to all lifting anchors

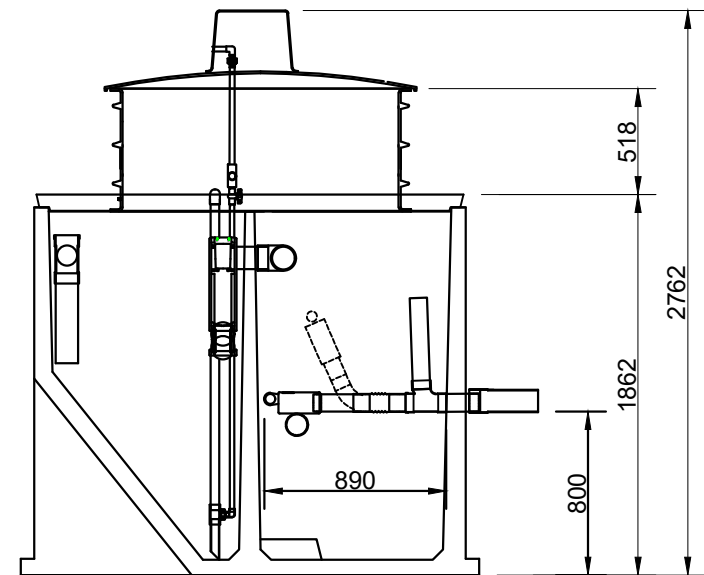

Section B-B



Christchurch Head Office
889 Jones Road, Rolleston
P O Box 16865, Hornby 8441,
Christchurch
0800 austin - 0800 287 846

ABS2000 FLOUT Treatment System

THE COPYRIGHT OF THIS DRAWING REMAINS WITH AUSTIN BLUEWATER ENVIRONMENTAL CONCEPTS LTD.

Product code:
ABS2000
Flout
136 Litres/dose

Scale: NTS
Drawn: GN
Date: 07/17
Rev:
Sep 2020