

ALL VOLUMES ARE APPROXIMATE

Gross Tank volume = 8.13 m³
 WORKING VOLUME = 6060 LITRES
 TREATMENT CAPACITY = 2200 LITRES/DAY

Lid thickness standard at 80mm. Recommended maximum loose soil cover depth - 400mm

TANK Weight - including 80 mm lid = 8.2 tonne
 Lifting - 4 number Reid 2.5 t eye anchors When handling an equalising beam must be used to ensure equal loading to all lifting anchors

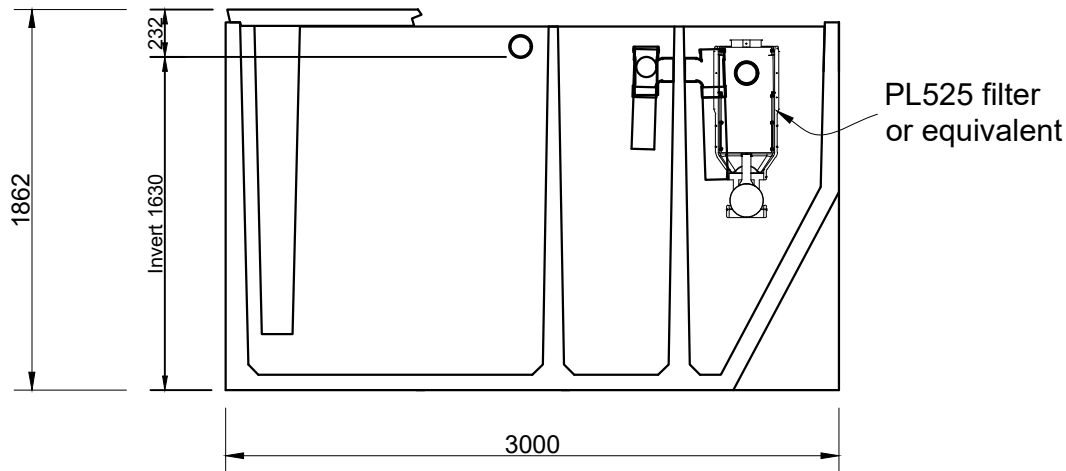

Section A-A

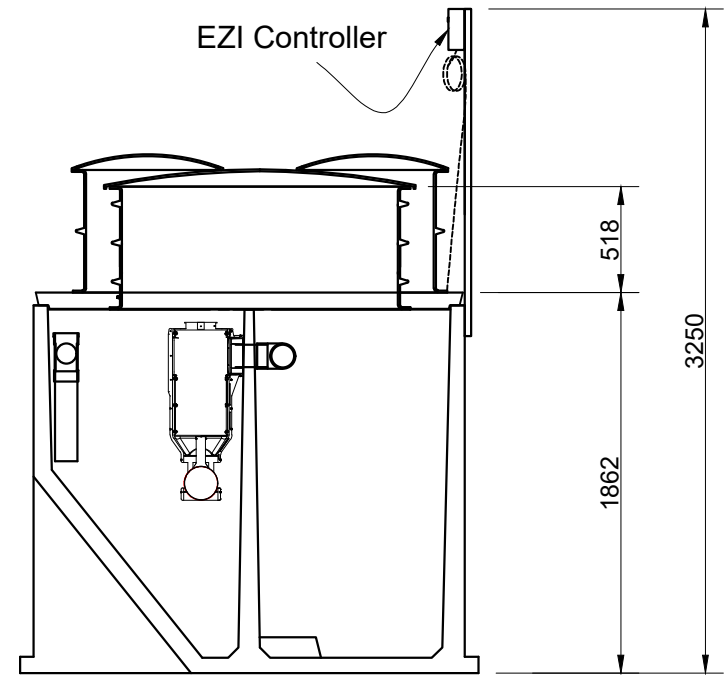

Section B-B

Rev	Date	Comments
A	11/24	Pump base extension



Christchurch Head Office
 20 Illinois Drive, Rolleston
 P O Box 16865, Hornby 8441,
 Christchurch
 0800 austin - 0800 287 846

B90 Septic Pumped (STEP)

THE COPYRIGHT OF THIS DRAWING REMAINS WITH AUSTIN BLUEWATER ENVIRONMENTAL CONCEPTS LTD.

Product code:	Scale: NTS
B90P	Drawn: GN
	Date: 11/24
	Rev: A