

LID thickness standard at 80mm.  
Recommended maximum loose soil cover depth - 400mm.

Light trafficable / heavy duty lids are available to order. Contact Austin Bluewater technical department

TANK Weight - with 80mm lid = 1.80 t  
Lifting - 2 No. Reid 1.3 eye anchors

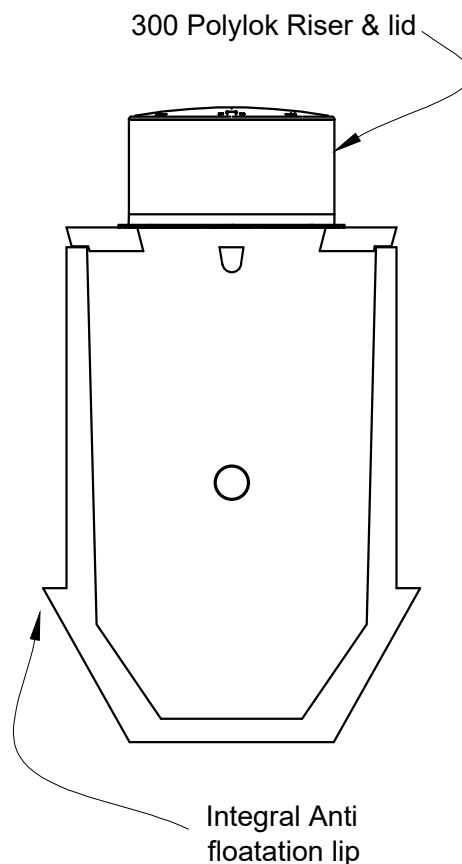
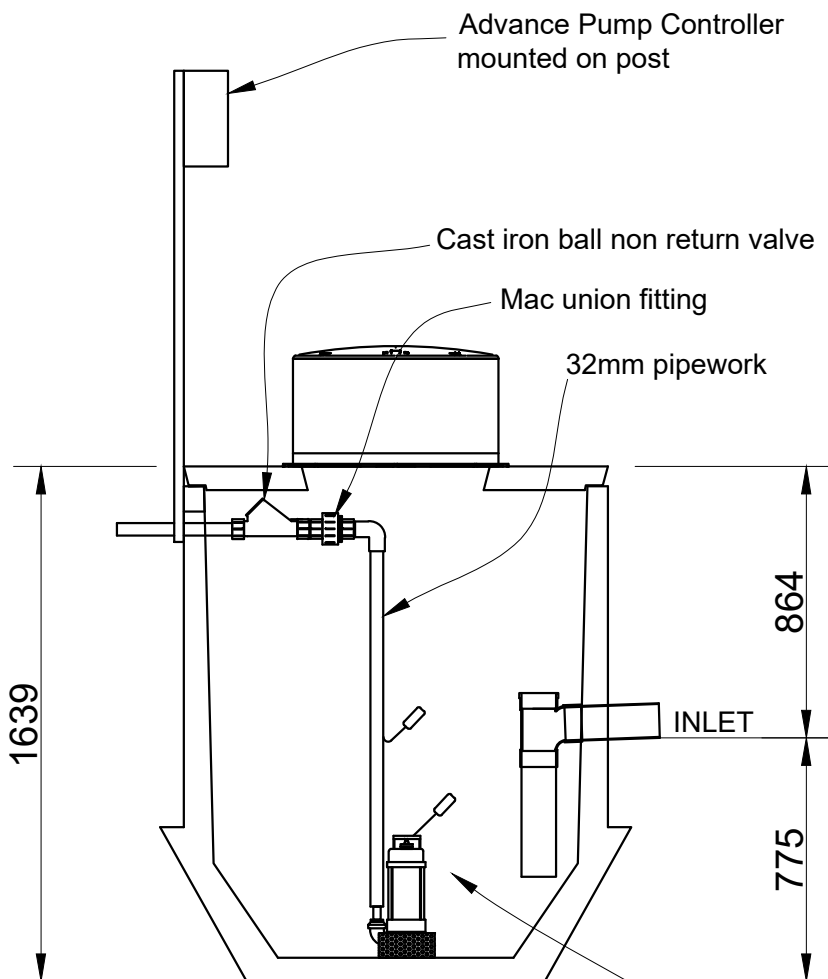

Blueline GDH-15 Macerating Pump. Refer Technical Department for pump duty. 32 mm dia pressure pipe plumbing.



Christchurch Head Office  
20 Illinois Drive, Rolleston  
P O Box 16865, Hornby 8441,  
Christchurch  
0800 austin - 0800 287 846

**MACERATING PUMP  
CHAMBER**

PC 1500 Litre Concrete construction

Product code:

**PC1500M**

Scale: NTS

Drawn: GN

Date: 07/17

Rev:

Sep 2023