

LID thickness standard at 80mm.
Recommended maximum loose soil cover depth - 400mm.

Light trafficable / heavy duty lids are available to order. Contact Austin Bluewater technical department

TANK Weight - with 80mm lid = 1.80 t
Lifting - 2 No. Reid 1.3 eye anchors

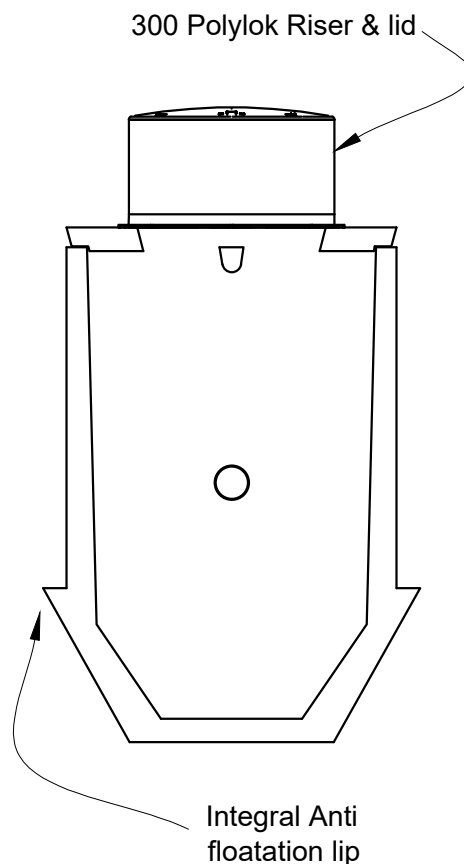
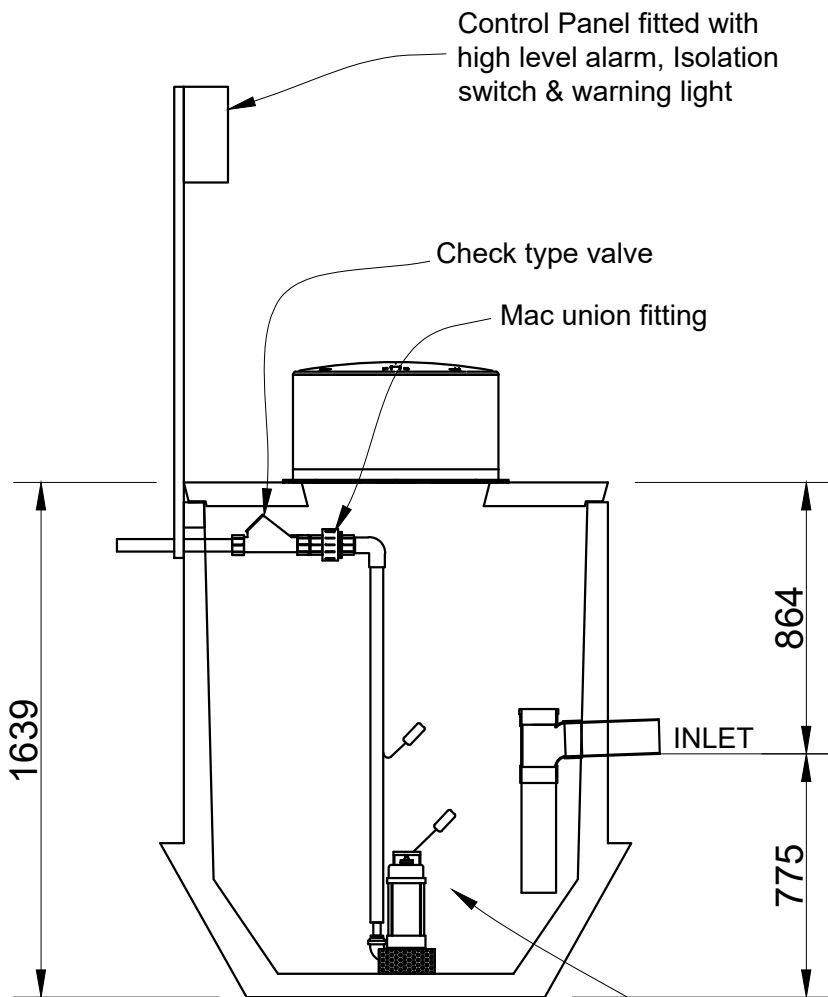

PUMP SYSTEM - Macerating, Vortex or Stormwater type pump, depending on application. Refer Technical Department for pump duty. 50 mm dia pressure pipe plumbing for Vortex or 32mm for Macerating.



Christchurch Head Office
20 Illinois Drive, Rolleston
P O Box 16865, Hornby 8441,
Christchurch
0800 austin - 0800 287 846

PUMP CHAMBER
PC 1500 Litre
Concrete construction

Product code:	Scale: NTS
PC1500	Drawn: GN
	Date: 07/17
Rev:	May 2023