

Section A-A

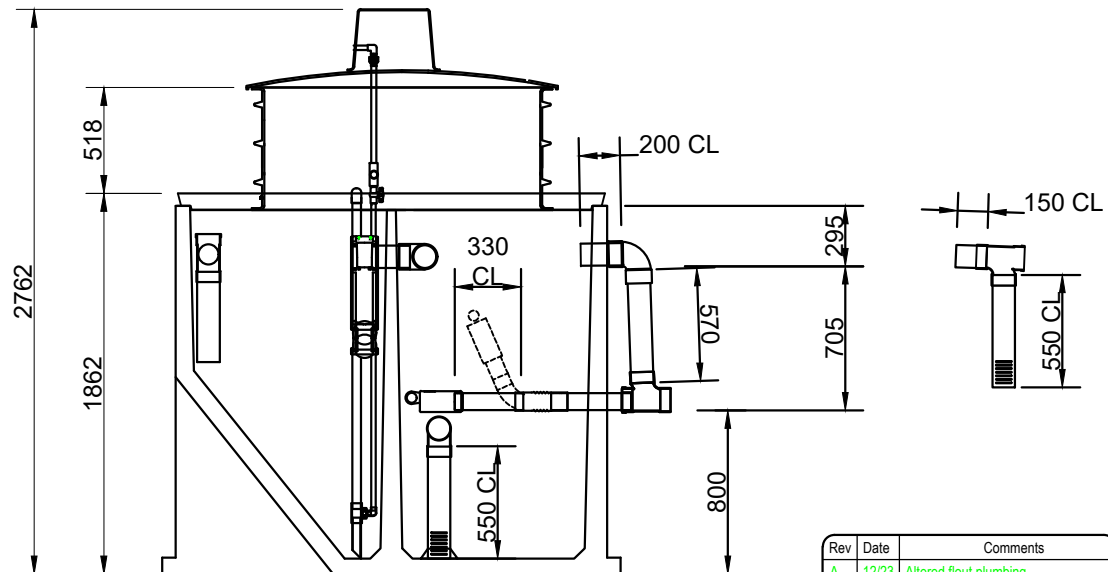

Section B-B

Rated to continuous flow of 1600 litres per day. Up to 2000 litres per day for intermittent use.

Lid thickness standard at 80mm. Recommended maximum loose soil cover depth - 400mm

Light Trafficable and heavy duty lids with cast iron frame and grates are available to order. Contact Austin Bluewater technical department.

TANK Weight - including 80 mm lid = 8.2 tonne  
Lifting - 4 number Reid 2.5 t eye anchors When handling an equalising beam must be used to ensure equal loading to all lifting anchors

Rev	Date	Comments
A	12/23	Altered flout plumbing



Christchurch Head Office  
20 Illinois Drive, Rolleston  
P O Box 16865, Hornby 8441,  
Christchurch  
0800 austin - 0800 287 846

## ABS2000 ULTRA FLOUT Treatment System

THE COPYRIGHT OF THIS DRAWING REMAINS WITH AUSTIN BLUEWATER ENVIRONMENTAL CONCEPTS LTD.

Product code: ABS2000 ULTRA Flout	Scale: NTS Drawn: GN Date: 08/18 Rev: <b>A</b>
---	---